

Content

1	General informations for disassembling the Pop Action Pilot.....	2
2	Purpose	2
3	Competences	2
4	Scope	2
5	Disclaimer.....	2
6	Qualified fitting personnel.....	2
7	Remarks.....	2
8	Basic safety guidelines	3
9	Disassembly Instructions.....	6

protected

disclosure cat.:	II	proofread:	Cal	published date:	tbd	effect. date:	02/12
author:	AW	released by:	KUW	replaces:	initial	status:	published
resp. depart.:	PP	date of release:	01/31/12	revision No.:	0		
doc. type:	LGS	change rep. No.:		retention period:	10y.		

1 General informations for disassembling the Pop Action Pilot

2 Purpose

The documentation describes the disassembly of the pop action pilot valve. The description contains every single working step, supplies, tools and appliances.

3 Competences

The generation, maintenance and distribution of the documentation takes place in the organisation department. The defaults will be generated by the technical department in consultation with the final assembly department and production planning department.

4 Scope

This document must be applied to the dismantling of a Pilot Operated Safety Valve in agencies and subsidiaries of LESER GmbH & Co. KG, customers and independent service center.

5 Disclaimer

LESER puts in a great deal of effort into making up-to-date and correct documentation available. Nevertheless, LESER GmbH & Co. KG gives no guarantee that the recommended actions presented here are entirely correct and error free. This document is to be applied exclusively to the specified type. LESER GmbH & Co. KG declines any liability or responsibility for the correctness and completeness of the content.

LESER GmbH & Co. KG reserves the right to change the information contained in this document, which is for the products of LESER GmbH & Co. KG and is intended for LESER subsidiaries, at any time and without prior announcement.

LESER GmbH & Co. KG is available to the users of this document to provide additional information.

6 Qualified fitting personnel

LESER safety valves may only be dismantled by trained or qualified fitters. The qualifications must be obtained through the appropriate training measures.

7 Remarks



Gloves must be worn during the entire dismantling process.

protected

disclosure cat.:	II	proofread:	Cal	published date:	tbd	effect. date:	02/12
author:	AW	released by:	KUW	replaces:	initial	status:	published
resp. depart.:	PP	date of release:	01/31/12	revision No.:	0		
doc. type:	LGS	change rep. No.:		retention period:	10y.		

8 Basic safety guidelines

Dangerous media

Poisoning, caustic burns, burns, injuries

- Use suitable protective devices
- Use suitable collecting tanks.
- Wear suitable protective equipment.

Foreign bodies in the safety valve

Danger from failure of safety valve or leaks

- Flush the system before installation of a safety valve.
- Check the safety valve for foreign objects.
- Remove foreign objects

Bug screen is damaged or missing (B or option)

Dirt, objects or insects get into the safety valve. Danger from malfunction of the safety valve.

- Install the bug screen correctly.
- Check the bug screen regularly.

Ambient temperature is too high

Material expansion. Danger from malfunction of the safety valve.

Ambient temperature is too low

Icing, freezing vapours, reduced flow rate due to congealing media. Danger from functional disruption of the safety valve.

Abrasive or corrosive media

Moving parts jam or become stuck. Danger from functional disruption of the safety valve.

- Service the safety valve after each time it opens.

Media with high proportion of particles (only B)

protected

disclosure cat.:	II	proofread:	Cal	published date:	tbd	effect. date:	02/12
author:	AW	released by:	KUW	replaces:	initial	status:	published
resp. depart.:	PP	date of release:	01/31/12	revision No.:	0		
doc. type:	LGS	change rep. No.:		retention period:	10y.		

Deposits and clogging. Danger from malfunction of the safety valve.

- Use a filter with the correct mesh size.
- Use additional filters to increase the filter capacity.

Residual media in the safety valve

Poisoning, caustic burns, burns, injuries

- Wear suitable protective equipment.
- Remove residual media

WARNING

Leaky safety valve

Danger from leaking media due to damaged gaskets and sealing surfaces.

- Protect the safety valve against vibrations and blows especially during transport and installation.
- Check safety valve regularly for leaks.

Open bonnet or spindle guides

Danger from leaking media

- Make sure that no danger can arise from leaking media.
- Keep a safe distance.
- Wear suitable protective equipment.

CAUTION

Hot medium

Burns or scalding.

- Wear suitable protective equipment.

Hot surfaces

Burns.

- Wear suitable protective equipment.

Aggressive medium

Caustic burns.

- Wear suitable protective equipment.

Open bonnet or spindle guides

disclosure cat.:	II	proofread:	Cal	published date:	tbd	effect. date:	02/12
author:	AW	released by:	KUW	replaces:	initial	status:	published
resp. depart.:	PP	date of release:	01/31/12	revision No.:	0		
doc. type:	LGS	change rep. No.:		retention period:	10y.		

protected

Pinching danger from moving parts.

- Install suitable safeguards.

Sharp edges and burrs

Danger of injury.

- Wear safety gloves.
- Handle the safety valve carefully

High noise emission

Hearing damage.

Wear ear protection.

protected

disclosure cat.:	II	proofread:	Cal	published date:	tbd	effect. date:	02/12
author:	AW	released by:	KUW	replaces:	initial	status:	published
resp. depart.:	PP	date of release:	01/31/12	revision No.:	0		
doc. type:	LGS	change rep. No.:		retention period:	10y.		

9 Disassembly Instructions

9.1 Removing the seal

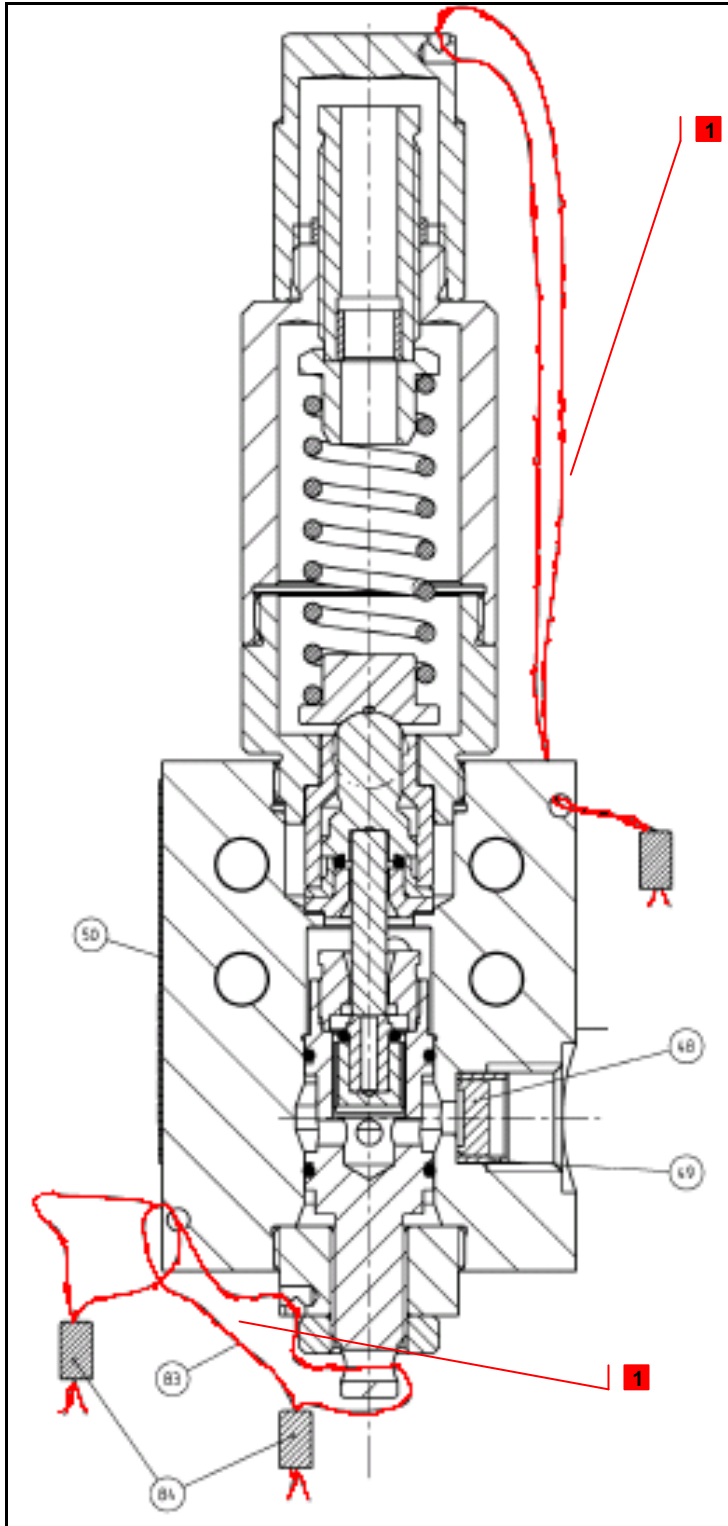

1. Steps – Descriptions

1 Cut wire with combination pliers

Pull out seal

protected

2. Supplies

None

3. Tools

Combination pliers

4. Appliance

None

disclosure cat.:	II	proofread:	Cal	published date:	tbd	effect. date:	02/12
author:	AW	released by:	KUW	replaces:	initial	status:	published
resp. depart.:	PP	date of release:	01/31/12	revision No.:	0		
doc. type:	LGS	change rep. No.:		retention period:	10y.		

9.2 Remove the cap and bug-screen

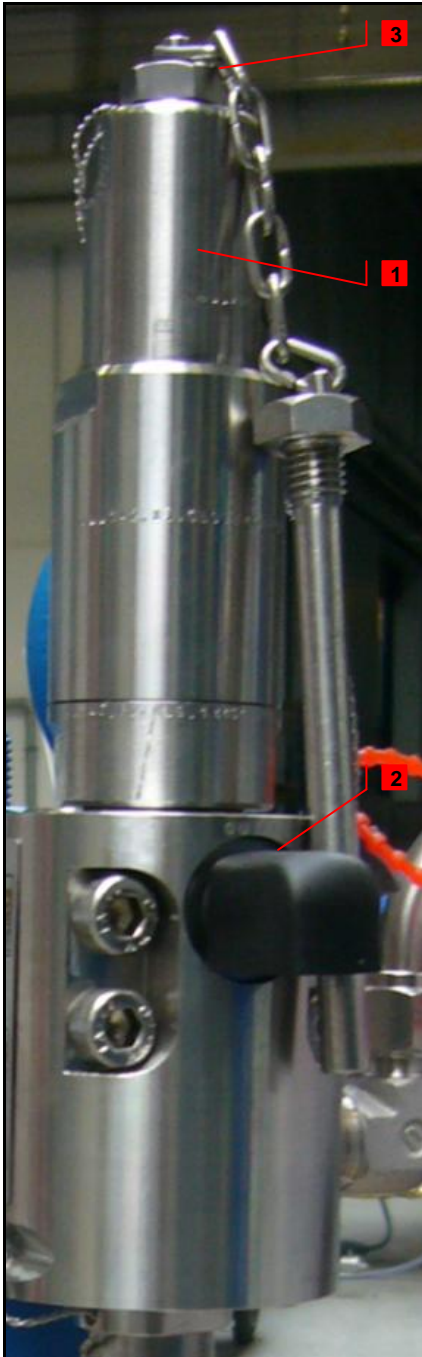

1. Steps – Descriptions

1 Loosen cap [40] and screw off

While loosening cap [40] counter bonnet [9]

2 Unscrew and remove bug-screen [64]

Option Test Gag:

3 Unscrew screw in the cap [40]

While loosening test gag counter bonnet [9]

2. Supplies

None

3. Tools

Open-end wrench acc. to LID

4. Appliance

Test bench

protected

disclosure cat.:	II	proofread:	Cal	published date:	tbd	effect. date:	02/12
author:	AW	released by:	KUW	replaces:	initial	status:	published
resp. depart.:	PP	date of release:	01/31/12	revision No.:	0		
doc. type:	LGS	change rep. No.:		retention period:	10y.		

9.3 Disassembly of Pilot Lifting Device

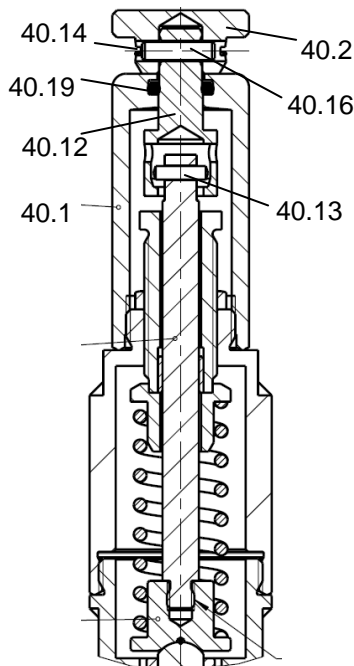

1. Steps – Descriptions

2 Tighten cap [40.1]. Put lifting button [40.2] and roll pin [40.16] on coupling [40.12]. Secure roll pin [40.16] with securing ring [40.14]

1 Place coupling [40.12] on the end of spindle [12] and insert parallel pin [40.13]

3 Put o-ring [40.19] in groove of cap [40.1]

4 Screw in spindle [12] into (lower) spring plate [17] hand-tight

Follow Error! Reference source not found. **for assembling of bonnet and spring**

5 Cover thread of spindle [12] with adhesive liquid Delo ML 5449

protected

2. Supplies

None

3. Tools

Open-end wrench acc. to LID
Drift pin

4. Appliances

Test bench

disclosure cat.:	II	proofread:	Cal	published date:	tbd	effect. date:	02/12
author:	AW	released by:	KUW	replaces:	initial	status:	published
resp. depart.:	PP	date of release:	01/31/12	revision No.:	0		
doc. type:	LGS	change rep. No.:		retention period:	10y.		

9.4 Disassembly of the bonnet and spindle unit

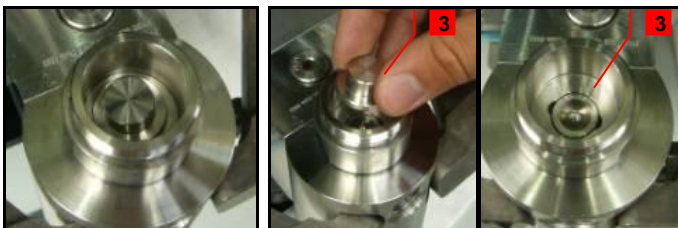
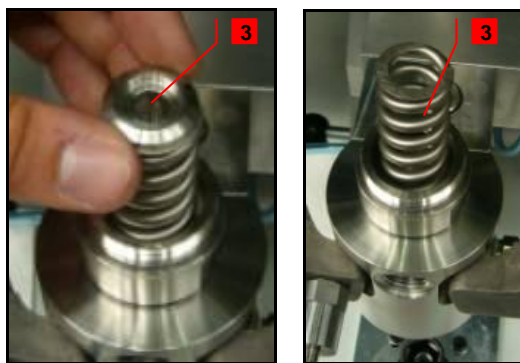
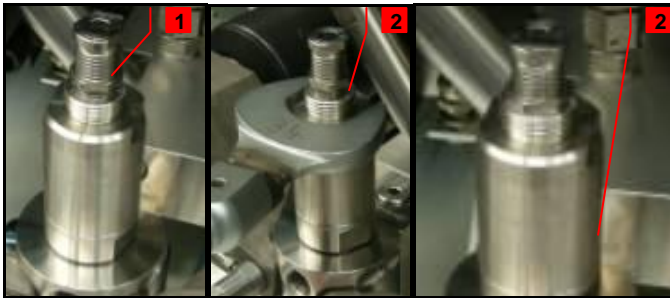

1. Steps – Descriptions

- 1** Loosen lock nut [19]
Apply an open-end wrench in a counterclockwise direction on adjusting screw [18] until no more pressure can be felt from spring.
- 2** Loosen bonnet [9] with open-end wrench and screw it off
- 3** Remove (upper) spring plate [16], spring and (lower) spring plate [17]

2. Supplies

None

3. Tools

Open-end wrench acc. to LID

4. Appliance

Test bench

protected

disclosure cat.:	II	proofread:	Cal	published date:	tbd	effect. date:	02/12
author:	AW	released by:	KUW	replaces:	initial	status:	published
resp. depart.:	PP	date of release:	01/31/12	revision No.:	0		
doc. type:	LGS	change rep. No.:		retention period:	10y.		

9.5 Disassembly of the bonnet

1. Steps – Descriptions



1 Screw adjusting screw unit out of bonnet [9]

2 Screw off lock nut [19]

3 Detach PTFE-bushing out of adjusting screw [18]

protected

2. Supplies

None

3. Tools

If necessary, in case of sluggishness
an open-end wrench

4. Appliance

Test bench

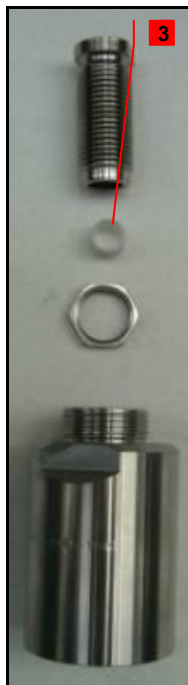

disclosure cat.:	II	proofread:	Cal	published date:	tbd	effect. date:	02/12
author:	AW	released by:	KUW	replaces:	initial	status:	published
resp. depart.:	PP	date of release:	01/31/12	revision No.:	0		
doc. type:	LGS	change rep. No.:		retention period:	10y.		

9.6 Disassembly of the body

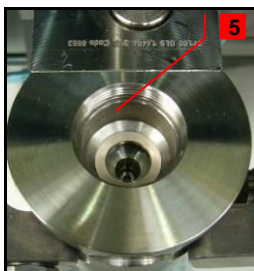
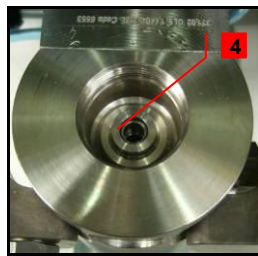
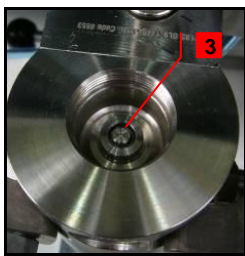
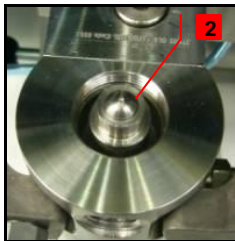

1. Steps – Descriptions

- 1** Screw off bonnet, base part [10] with open-end wrench
- 2** Remove piston guide [11] and guide [2]
- 3** Remove plunger [15]
- 4** Remove (upper) seat, exhaust [13] and (lower) seat, exhaust [14]
- 5** Remove gasket [35]

protected

2. Supplies

None

3. Tools

Open-end wrench acc. to LID

4. Appliance

Test bench

disclosure cat.:	II	proofread:	Cal	published date:	tbd	effect. date:	02/12
author:	AW	released by:	KUW	replaces:	initial	status:	published
resp. depart.:	PP	date of release:	01/31/12	revision No.:	0		
doc. type:	LGS	change rep. No.:		retention period:	10y.		

9.7 Disassembly of the seat

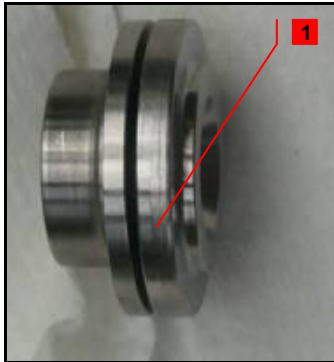

1. Steps – Descriptions

1 Separate seat by pulling (upper) seat, exhaust [13] and (lower) seat , exhaust [14] apart

protected

2. Supplies

None

3. Tools

None

4. Appliance

None

disclosure cat.:	II	proofread:	Cal	published date:	tbd	effect. date:	02/12
author:	AW	released by:	KUW	replaces:	initial	status:	published
resp. depart.:	PP	date of release:	01/31/12	revision No.:	0		
doc. type:	LGS	change rep. No.:		retention period:	10y.		

9.8 Removing the adjusting screw

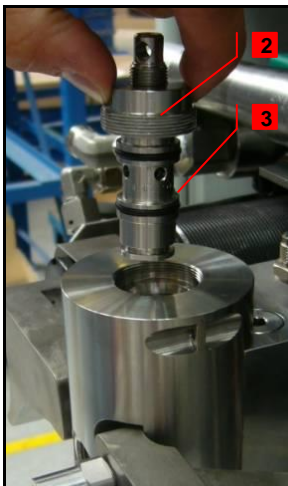
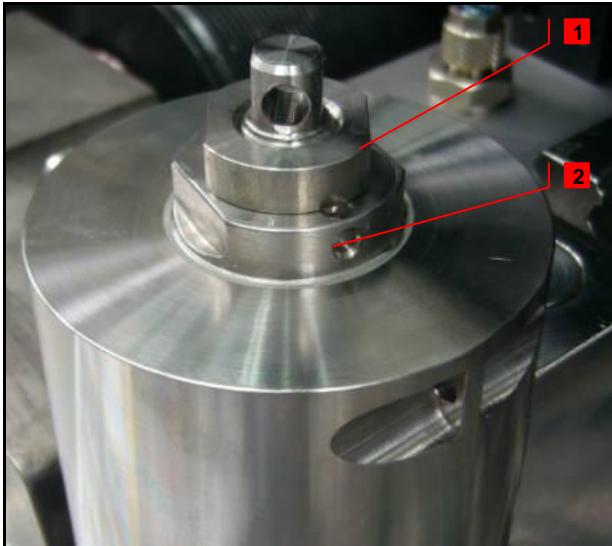

1. Steps – Descriptions



Measure adjustment of adjusting screw [12] to establish same adjustment after refinishing pilot valve

- 1** Loosen and remove counter nut [21]
- 2** Loosen nut [20] of adjusting screw [12]
- 3** Pull out adjusting screw [12]

protected

2. Supplies

None

3. Tools

Hook tool for O-rings
Open-end wrench acc. to LID

4. Appliance

Test bench

disclosure cat.:	II	proofread:	Cal	published date:	tbd	effect. date:	02/12
author:	AW	released by:	KUW	replaces:	initial	status:	published
resp. depart.:	PP	date of release:	01/31/12	revision No.:	0		
doc. type:	LGS	change rep. No.:		retention period:	10y.		

9.9 Disassembly of the adjusting screw



1. Steps – Descriptions

1 Unscrew nut [20] of adjusting screw [12] with open-end wrench

2 Remove O-rings with hook tool

3 Place adjusting screw [12] in assembling aid pilot (optional: parallel vice with aluminium jaws). Unscrew seat, feeding [5] and screw it off the adjusting screw [12] with open-end wrench

4 Pull (upper) disc feeding [7] and (lower) disc feeding [8] out of adjusting screw [12]

6 Pull (upper) disc, feeding [7] out of (lower) seat feeding [8]
Remove O-Ring 6,07x1,78 [30] from (upper) disc feeding [7]

2. Supplies

None

3. Tools

Open-end wrench acc. to LID
Hook tool for O-ring
Drift pin

4. Appliance

Parallel vice with aluminium jaws
Or as recommended with Assembling aid (60S.2512.4012)

protected

disclosure cat.:	II	proofread:	Cal	published date:	tbd	effect. date:	02/12
author:	AW	released by:	KUW	replaces:	initial	status:	published
resp. depart.:	PP	date of release:	01/31/12	revision No.:	0		
doc. type:	LGS	change rep. No.:		retention period:	10y.		

9.10 Disassembly of the manifold block

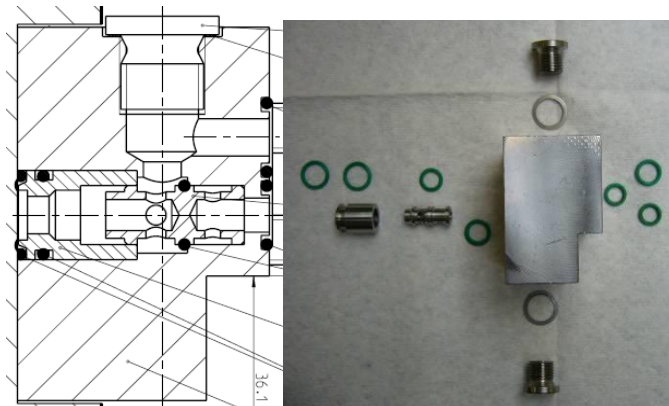
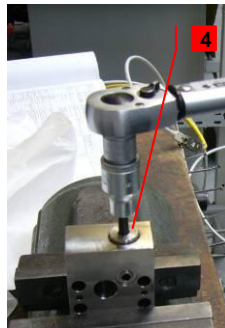
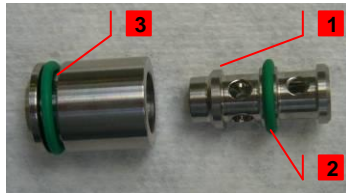
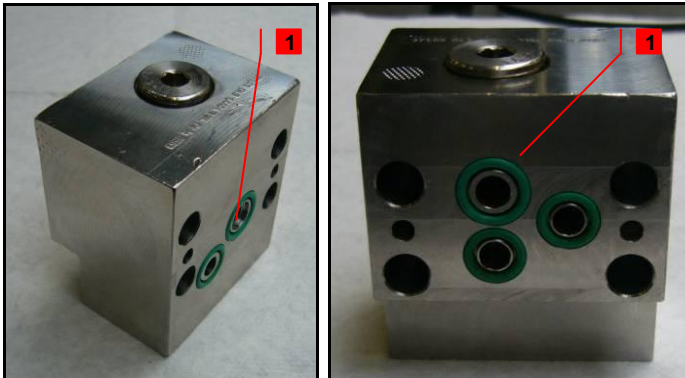

1. Steps – Descriptions

- 1** Remove piston [24.3], bushing [24.2] and O-rings
- 2** Remove O-rings of piston [24.3]
- 3** Remove O-rings of bushing [24.2]
- 4** Screw off lock screw [24.7] and take out gasket [24.8]

2. Supplies

None

3. Tool

Allen key acc. to LID
Hook tool for O-rings

4. Appliance

Parallel vice with aluminium jaws
Test bench

protected

disclosure cat.:	II	proofread:	Cal	published date:	tbd	effect. date:	02/12
author:	AW	released by:	KUW	replaces:	initial	status:	published
resp. depart.:	PP	date of release:	01/31/12	revision No.:	0		
doc. type:	LGS	change rep. No.:		retention period:	10y.		